



PROJECT TITLE:
ECSCO GmbH
Kanzler

DRAWING TITLE:
CONSTANT TEMPERATURE
& HUMIDITY EQUIPMENT
RST-1148-IX
(1 CYCLE)

SCALE: S/N

DATE: 2009.08.11

FILE NAME:

DWG NO:

DRAWING GRADE:

REQUEST NO:

LEGEND:

APPROVED

CHECKED

DESIGNED

DRAWING

SPECIFICATION	
SPEC MODEL	RST-1148-IX
COOLING CAPACITY	14,000 kcal/h (16.2 kW)
BLOWER MOTOR	55 CMM
MOTOR	3 PH/60 HZ/0.55 KW x 6 P
COMPRESSOR	HERMETIC SCROLL
EVAPORATOR	3 PH/60 HZ/3.75 KW
	MULTI-PASS CROSS FINNED TUBE
	SPEC
HEATER	CAPACITY 6.02D kcal/h (7 kW)
	TYPE SUS-AERO FINNED TUBE TYPE
	STEP 2.34 kW x 3 STEP
HUMIDIFIER	CAPACITY 4 L/h
	TYPE ELECTRODE
	STEP 3 KW
AIR FILTER	TYPE VINYL CHLORIDE + POLYESTER 20I
	SIZE 920 x 390 x 1EA
FRAME SIZE	SIZE 900 x 800 x 2050
REFRIGERANT	R - 407-C

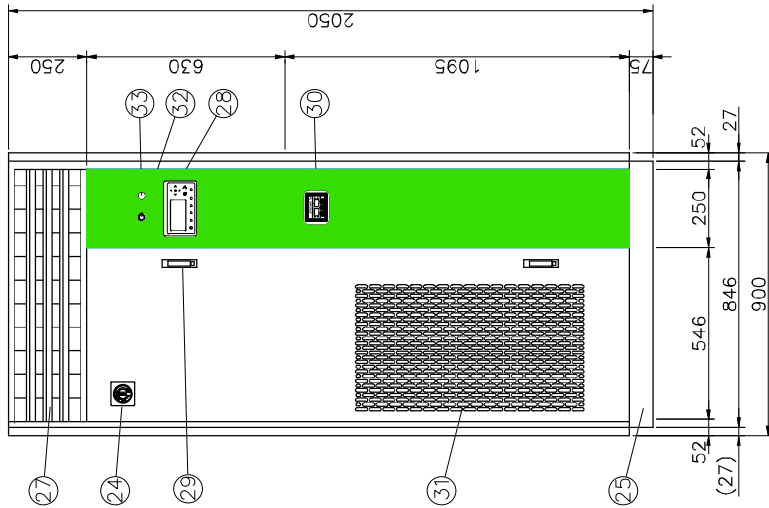
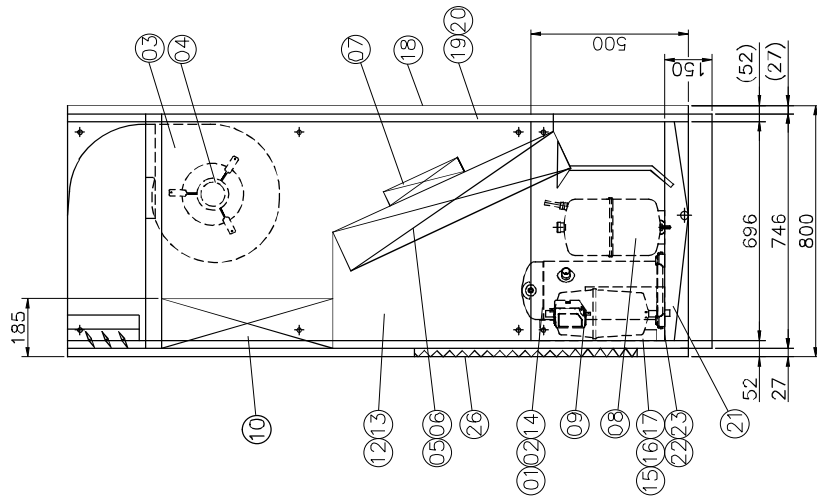
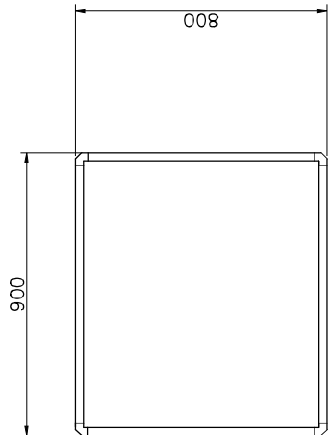

REV	DATE	DESCRIPTION	REVIEWED	CHECKED